

FEATURES

- Aluminum or stainless steel body
- Tension and Compression
- Heavy duty
- Sealed version optional
- Easy to customize threads

APPLICATIONS

- Dynamic strain cylinder regulation
- Miniature press-fit device
- Laboratory
- Robotics regulation
- Small size actuators

XFTC321

Miniature Load Cell

SPECIFICATIONS

- **Range from 0-500N to 0-10kN**
[0-100 lbf to 2 klb]
- **Tension and/or Compression**
- **Threaded Female Mechanical Fitting**

The **XFTC321** series has been specifically developed to measure tension and compression in static and dynamic applications. The miniature size facilitates testing where space is at a premium.

The sensing element is fitted with a fully temperature compensated Wheatstone bridge equipped with high stability micro-machined silicon strain gages. The use of silicon strain gages optimizes the load cell's performance at low ranges and frequencies.

A strain relief spring strengthens the cable output. With two female threads, the **XFTC321** is easily installed in industrial or OEM applications.

On request, Instruction documents can be provided to ease the selection and use of our sensors and provide helpful tips.

STANDARD RANGES

Ranges in N (FS)	500 - 1k	2k	5k - 10k
Ranges in lbf	100 - 200	400	1k - 2k
Stiffness in N/m	3x10 ⁷	1x10 ⁸	2x10 ⁹ to 4x10 ⁹
Stiffness in lbf/ft	2.10x10 ⁶ to 4.1x10 ⁶	6.9x10 ⁶	1.4x10 ⁸ to 2.7x10 ⁸
Materials	Aluminum Alloy	Stainless Steel	

PERFORMANCE SPECIFICATIONS (typical values at temperature 23±3°C)

PARAMETERS	
Operating Temperature Range (OTR)	-40 to 120° C [-40 to 248° F]
Compensated Temperature Range (CTR)	0 to 60° C (32 to 140° F)
Thermal Zero Shift in CTR	<2% F.S. / 50° C [/100° F]
Thermal Sensitivity Shift in CTR	<2% of reading / 50° C [/100° F]
Range (F.S.)	0-500N to 0-10kN [0-100 lbf to 0-2klbf]
Over-Range	
Without Damage	2 x F.S.
Without Destruction	3 x F.S.
Accuracy	
Linearity	≤±0.5% F.S.
Hysteresis	≤±0.5% F.S.

Electrical Characteristics

Model	XFTC321
Supply Voltage	10Vdc
Sensitivity "FSO"	±5 mV/V for 500N model ±10 mV/V for models ≥ 1kN
Zero Offset	<±10 mV
Input Impedance/Consumption	1000 to 3000Ω
Output Impedance	500 to 1000Ω
Insulation under 50Vdc	≥100MΩ

Notes

1. Shielded cable with 4 wires (AWG36/28), standard length 2 m [6.5 ft] with strain relief spring
2. Material: Body in stainless steel or aluminum alloy depending on F.S.
3. Protection Index: IP50 (other levels available on request)
4. CE conformance according to EN 61010-1, EN 50081-1, EN 50082-1

DIMENSIONS & WIRING SCHEMATIC (IN METRIC AND IMPERIAL)

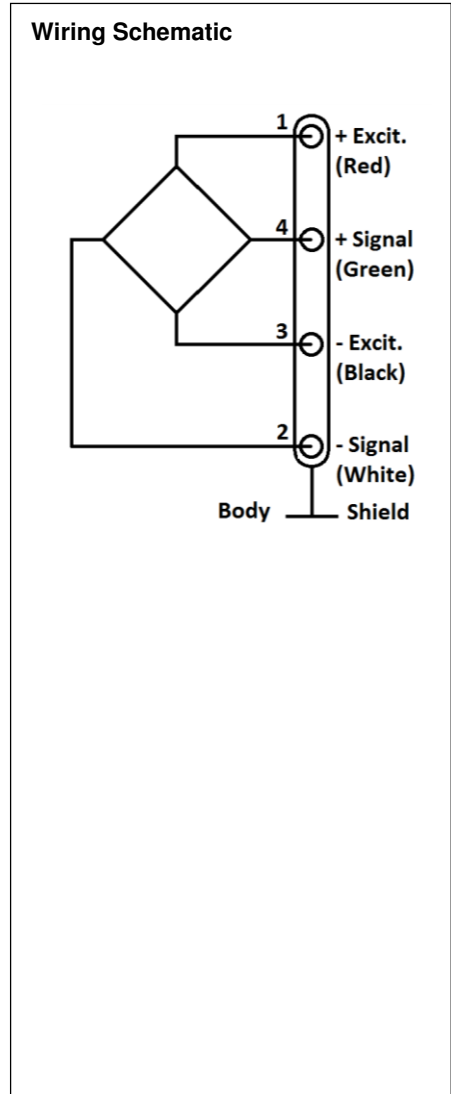
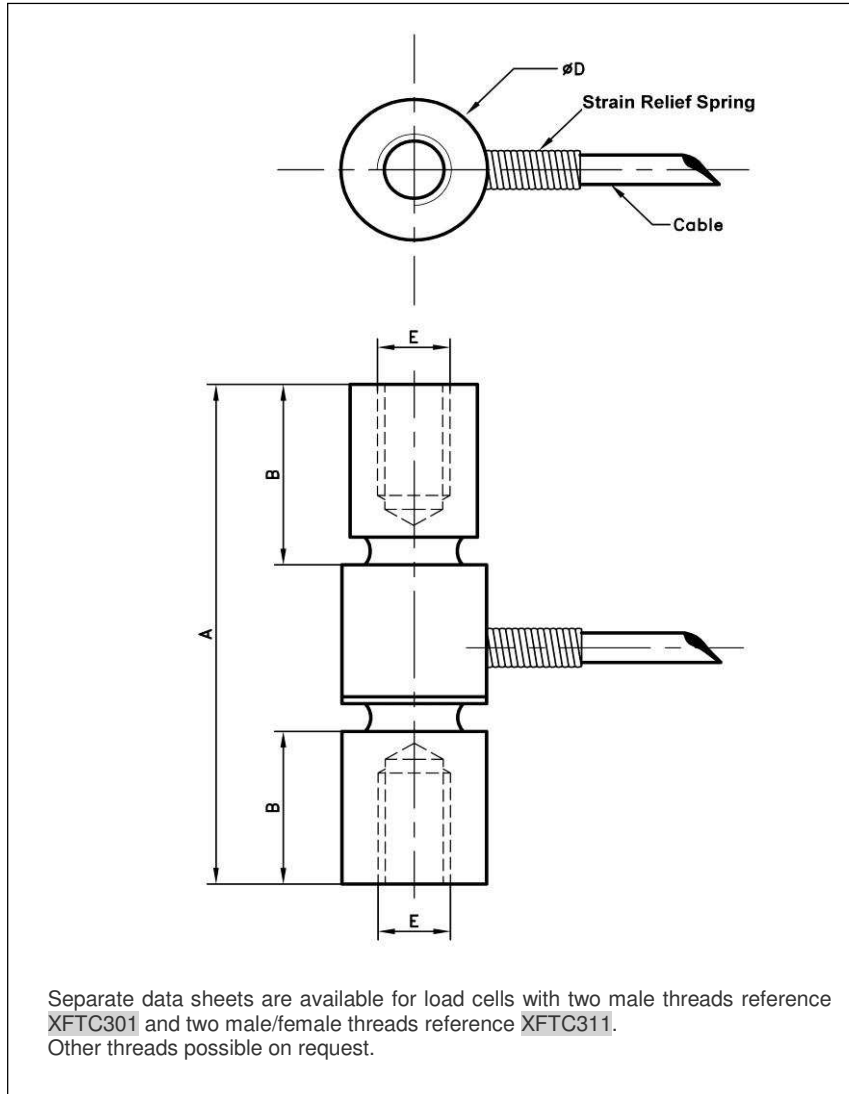

Dimensions in mm [inch]

Full Scale Range in N [in lbf]	500-1k [100 - 200]	2k [400]	5k-10k [1k - 2k]
A	36 [1.42]		46 [1.81]
B	11 [0.43]		13 [0.51]
C	12.5 [0.49]		14 [0.55]
$\varnothing D$	10 [0.39]		16 [0.63]
E Thread	M5		M10
Internal depth	8 [0.31]		10 [0.39]
Material	Aluminum	Stainless Steel	Stainless Steel
Stiffness in N/m	3×10^7	1×10^8	2×10^9 to 4×10^9
Stiffness in lbf/ft	2.1×10^6 to 4.1×10^6	6.9×10^6	1.4×10^8 to 2.7×10^8

XFTC321

Miniature Load Cell

OPTIONS

ET1	: CTR -20 to 100° C [-4 to 212° F]
ET2	: CTR -40 to 120° C [-40 to 248° F]
ET3	: CTR -40 to 150° C [-40 to 302° F] OTR=CTR
HA	: Accuracy (CNL&H) $\leq \pm 0.5\%$ F.S.
L00M	: special cable length, replace "00" with total length in meters

ORDERING INFO

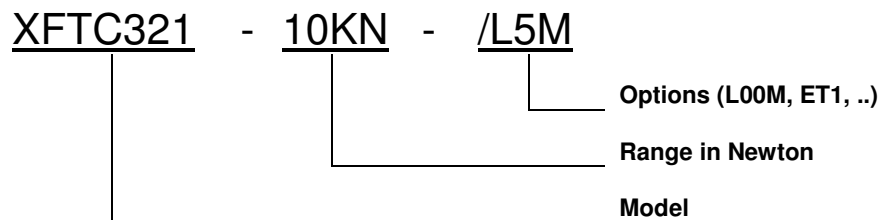

NORTH AMERICA

Measurement Specialties, Inc.,
a TE Connectivity Company
Vibration Design Center
32 Journey - Suite 150
Aliso Viejo, CA 92656
United States USA
Tel: 1-949-716-0877
Fax: 1-949-916-5677
t&m@meas-spec.com

EUROPE

Measurement Specialties (Europe), Ltd.,
a TE Connectivity Company
26 Rue des Dames
78340 Les Clayes-Sous-Bois, France
Tel: +33 (0) 130 79 33 00
Fax: +33 (0) 134 81 03 59
cs.lcsb@meas-spec.com

ASIA

Measurement Specialties (China), Ltd.,
a TE Connectivity Company
No. 26 Langshan Road
Shenzhen High-Tech Park (North)
Nanshan District, Shenzhen 518057
China
Phone: +86-755-33305088
Fax: +86-755-33305099
pfg.cs.asia@meas-spec.com

TE.com/sensorsolutions

Measurement Specialties, Inc., a TE Connectivity company.

Measurement Specialties, TE Connectivity, TE Connectivity (logo) and EVERY CONNECTION COUNTS are trademarks. All other logos, products and/or company names referred to herein might be trademarks of their respective owners.

The information given herein, including drawings, illustrations and schematics which are intended for illustration purposes only, is believed to be reliable. However, TE Connectivity makes no warranties as to its accuracy or completeness and disclaims any liability in connection with its use. TE Connectivity's obligations shall only be as set forth in TE Connectivity's Standard Terms and Conditions of Sale for this product and in no case will TE Connectivity be liable for any incidental, indirect or consequential damages arising out of the sale, resale, use or misuse of the product. Users of TE Connectivity products should make their own evaluation to determine the suitability of each such product for the specific application.

© 2015 TE Connectivity Ltd. family of companies All Rights Reserved.