



✓RoHS

82 Vacuum Gage (Compensated)

SPECIFICATIONS

- 316L SS Pressure Sensor
- 19mm Diameter Package
- 0 - 100mV Output
- Vacuum Gage
- Temperature Compensated

The 82 vacuum gage is a 19 mm small profile, media compatible, piezoresistive silicon pressure sensor packaged in a 316L stainless steel housing. The 82 vacuum gage can be configured for o-ring mounting or threaded process fittings and is designed for OEM applications where compatibility with corrosive media is required.

The sensing package utilizes silicone oil to transfer pressure from the 316L stainless steel diaphragm to the sensing element. A ceramic substrate is attached to the package that contains laser-trimmed resistors for temperature compensation and offset correction. An additional laser-trimmed resistor is included which can be used to adjust an external differential amplifier and provide span interchangeability to within $\pm 1\%$.

Please refer to the 82 uncompensated, compensated and constant voltage datasheets for more information on different features of the 82.

FEATURES

- O-Ring Mount/Threaded Process Fittings
- -40°C to +125°C Operating Temperature Range
- Up to $\pm 0.1\%$ Pressure Non Linearity
- 1.0% Interchangeable Span (provided by gain set resistor)
- Solid State Reliability

APPLICATIONS

- Medical Instruments
- Process Control
- Fresh & Waste Water Measurements
- Partial Vacuum Gas Measurement
- Pressure Transmitters
- Tank Level Systems (RV & Industrial)

STANDARD RANGES

Range	psiv
0 to 15	•
0 to 30	•
0 to 50	•
0 to 100	•
0 to 300	•
0 to 500	•

PERFORMANCE SPECIFICATIONS

Supply Current: 1.5mA

Ambient Temperature: 25°C (unless otherwise specified)

PARAMETERS	MIN	TYP	MAX	UNITS	NOTES
Span	75	100	150	mV	1
Zero Pressure Output	-1.0	0	1.0	mV	2
Pressure Non Linearity	-0.20		0.20	%Span	3
Pressure Hysteresis	-0.05	±0.02	0.05	%Span	
Repeatability		±0.02		%Span	
Input Resistance	2000	3500	5800	Ω	
Output Resistance	4000		6000	Ω	
Temperature Error – Span	-0.75		0.75	%Span	4
Temperature Error – Offset	-0.75		0.75	%Span	4
Thermal Hysteresis – Span	-0.25	±0.05	0.25	%Span	4
Thermal Hysteresis – Offset	-0.25	±0.05	0.25	%Span	4
Long Term Stability – Span		±0.10		%Span/year	
Long Term Stability – Offset		±0.10		%Span/year	
Supply Current	0.5	1.5	2.0	mA	5
Output Load Resistance	5			MΩ	6
Insulation Resistance (50Vdc)	50			MΩ	7
Output Noise (10Hz to 1KHz)		1.0		uV p-p	
Response Time (10% to 90%)		0.1		ms	
Pressure Overload			3X	Rated	
Pressure Burst			4X	Rated	8
Compensated Temperature	-20		+85	°C	
Operating Temperature	-40		+125	°C	9
Storage Temperature	-50		+125	°C	9
Media – Pressure Port	Liquids and Gases compatible with 316L Stainless Steel				

Notes

1. For amplified output circuits, 3.012V ±1% interchangeability with gain set resistor. See application schematic.
2. Measured at ambient for vacuum gage (V).
3. Best fit straight line. For pressure range 15 - 100psi, PNL is ±0.1% Span.
4. Over the compensated temperature range with respect to 25°C.
5. Guarantees output/input ratiometricity.
6. Load resistance to reduce measurement errors due to output loading.
7. Between case and sensing element.
8. The maximum pressure that can be applied to a transducer without rupture of either the sensing element or transducer.
9. The maximum temperature range for product with standard cable and connector is -20°C to +105°C.

DIMENSIONS

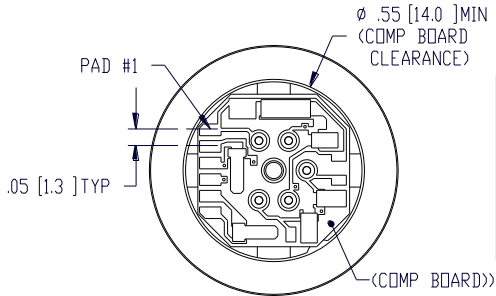
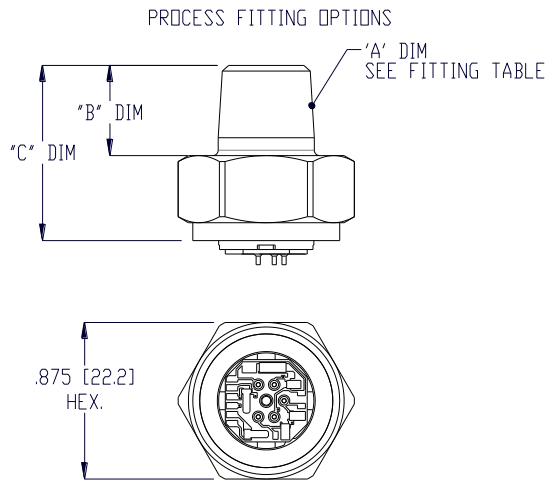
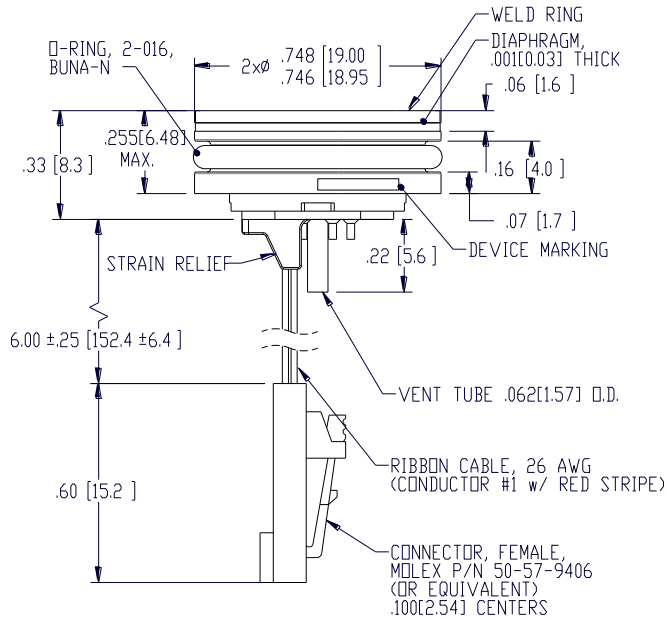

PAD NO	FUNCTION
1	+OUT
2	-EX
3	+EX
4	-OUT
5	
6	GAIN

FITTING TABLE				
FITTING TYPE	MEMS P/N	'A' DIM	'B' DIM	'C' DIM
1	IC-7152	1/4-18 NPT	.50[12.7]	.98[24.9]
2	IC-D00510	1/8-27 NPT	.47[11.9]	.95[24.1]
3	IC-D00511	7/16-20 UNF	.33[8.4]	.80[20.3]
9	IC-D00512	1/4-19 BSP	.45[11.4]	.93[23.3]

NOTE: FITTING TYPE '1' ASSEMBLY SHOWN
ALL DIMS ARE FOR REFERENCE.

VIEW SHOWN W/O CABLE AND CONNECTOR FOR CLARITY
DIMENSIONS ARE IN INCHES [mm]

APPLICATION SCHEMATIC

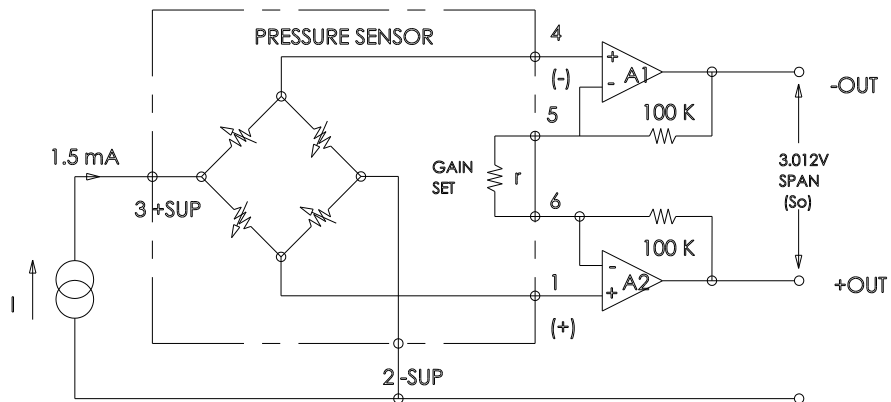

ORDERING INFORMATION

82	-	050	V	-	1	C	T
Model	-	Pressure Range	Pressure Type	-	Fitting Type	Electrical	Vent
82	-	015 030 050 100 300 500	V = Vacuum Gage	-	Blank = O-Ring Mount 1 = 1/4-18NPT 2 = 1/8-27 NPT 3 = 7/16-20UNF 9 = 1/4-19BSP	P = Solder Pads R = Ribbon Cable C = Cable w/ Connector	Blank = No Tube T = Tube

NORTH AMERICA

Measurement Specialties, Inc.,
a TE Connectivity Company
45738 Northport Loop West
Fremont, CA 94538
Tel: 1-800-767-1888
Fax: 1-510-498-1578
Sales: pfg.cs.amer@meas-spec.com

EUROPE

Measurement Specialties (Europe), Ltd.,
a TE Connectivity Company
26 Rue des Dames
78340 Les Clayes-sous-Bois, France
Tel: +33 (0) 130 79 33 00
Fax: +33 (0) 134 81 03 59
Sales: pfg.cs.emea@meas-spec.com

ASIA

Measurement Specialties (China), Ltd.,
a TE Connectivity Company
No. 26 Langshan Road
Shenzhen High-Tech Park (North)
Nanshan District, Shenzhen 518057
China
Tel: +86 755 3330 5088
Fax: +86 755 3330 5099
Sales: pfg.cs.asia@meas-spec.com

TE.com/sensorsolutions

Measurement Specialties, Inc., a TE Connectivity company.

Measurement Specialties, TE Connectivity, TE Connectivity (logo) and EVERY CONNECTION COUNTS are trademarks. All other logos, products and/or company names referred to herein might be trademarks of their respective owners.

The information given herein, including drawings, illustrations and schematics which are intended for illustration purposes only, is believed to be reliable. However, TE Connectivity makes no warranties as to its accuracy or completeness and disclaims any liability in connection with its use. TE Connectivity's obligations shall only be as set forth in TE Connectivity's Standard Terms and Conditions of Sale for this product and in no case will TE Connectivity be liable for any incidental, indirect or consequential damages arising out of the sale, resale, use or misuse of the product. Users of TE Connectivity products should make their own evaluation to determine the suitability of each such product for the specific application.

© 2015 TE Connectivity Ltd. family of companies All Rights Reserved.