

## SmartBlock I/O Module

### HE579DIQ880 – 8DC Inputs, 8 Relay Outputs

### HE579DIQ881 - 8DC Inputs, 8 DC Outputs

#### 1. SPECIFICATIONS

DIQ880 & DIQ881 Digital DC Inputs		
Inputs per Module	8	
Commons per Module	1	
Input Voltage Range	12 VDC / 24 VDC	
Absolute Max. Voltage	35 VDC max.	
Input Impedance	10KΩ	
Input Current	Positive Logic	Negative Logic
Current Max. Upper Threshold	0.8mA	-1.6mA*
Current Min. Lower Threshold	0.3mA	-2.1mA*
Voltage Max. Upper Threshold	8 VDC	
Voltage Min. Lower Threshold	3 VDC	

DIQ881 Digital DC Outputs	
Outputs per Module	8
Commons per Module	1
Output Type	Sourcing, active pull-down
Max. Output Current per Point	2.5A
Max. Total Output Current	10A
Output Supply Voltage (VS)	9-30VDC
Response Time	Network Time + 10ms
Voltage Drop @ Rated Current	1V
Protection	Short circuit, Overtemp, Automatic Reset
Max. Switching Rate	Limited by message rate

\*24VDC Supply Voltage

DIQ880 Digital Relay Outputs	
Outputs per Module	8 relay
Commons per Module	8
Max. Output Current per Relay	3A @ 250 VAC, resistive
Max. Total Output Current	25A continuous
Max. Output Voltage	275 VAC, 30 VDC
Response Time	Network Time + 10ms
Max Switched Power	1250VA, 150W
Contact Isolation to Bus/Ground Power	1000 VAC
Max. Voltage Drop at Rated Current	0.5V
Expected Life	No load: 5,000,000 Rated load: 100,000
Max. Switching Rate	300 CPM @ no load 20 CPM @ rated load
Type	Mechanical Contact

General Specifications	
Voltage Input (V+)	10-30 VDC
Relative Humidity	5 to 95% non-condensing
Required Power (Steady State)	2W (80mA @ 24 VDC)
Required Power (InRush)	DC Switched: 12A 50μS AC Switched: 120mA 10ms
Operating Temperature	0° to 60° C
Weight	12 oz. / 340 g

#### NOTES:

- A. I/O common pins, C, are internally connected to the power supply negative.
- B. Digital inputs are configurable for positive or negative logic using Cscope.
- C. When configured for positive logic, the inputs are pulled down to common by a 10K resistor. When an input is open or low, the associated LED is OFF and the associated OCS register bit is 0. When an input is driven high above the threshold level, the associated LED turns ON, and the associated OCS register bit is 1.
- D. When configured for negative logic, the inputs are pulled up to the positive supply voltage, V+, by a 10K resistor. When an input is open or high, the associated LED is OFF and the associated OCS register bit is 0. When an input is driven low, below the threshold, the associated LED turns ON, and the associated OCS register bit is 1.

#### 2. CAN Wiring

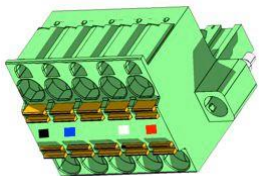

CAN Network & Power Connector  
Torque rating 4.5 – 7 Lb.-In. (0.50 – 0.78 N-m)

CAN Network & Power Port Pin Assignments			
Pin	Signal	Signal Descriptions	Direction
1	V-	CAN & Device Ground – Black	-
2	CN_L	CAN Data Low - Blue	In/Out
3	SHLD	Shield Ground - None	-
4	CN_H	CAN Data High - White	In/Out
5	V+	Positive DC Voltage Input (10-30 VDC) - Red	-

#### Network, Power, and Grounding:

A single 5 pin connector is used to make both a network connection and power input. A quality class 2 power supply should be used for this product. If the power is run with the network cable, care must be taken such that the voltage does not drop below the lower supply limit on longer runs.

A quality earth ground is required for safe and proper operation. The best ground is achieved by screwing the lower left grounding location into a grounded back plate. Alternately, a ground can be connected to the spade lug.

Please see Horner manual MAN0799 for details on CAN wiring.

### 3. INTERNAL WIRING

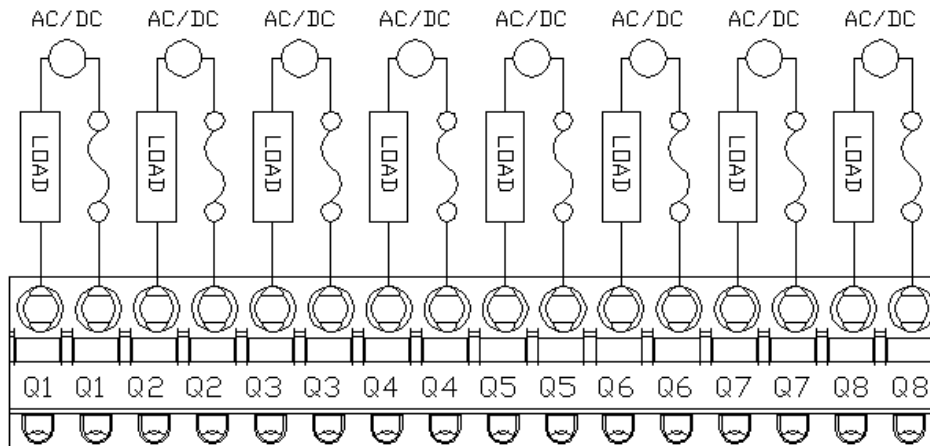

Figure 1 - HE57DIQ880 Outputs

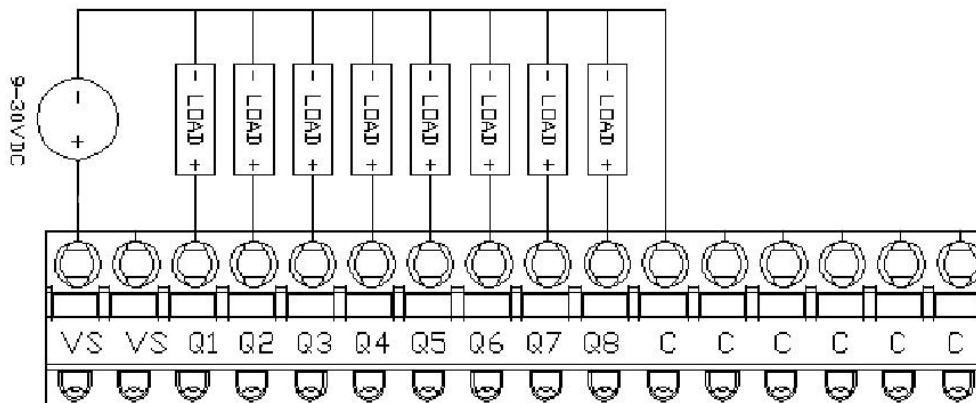

Figure 2 - He579DIQ881 Outputs

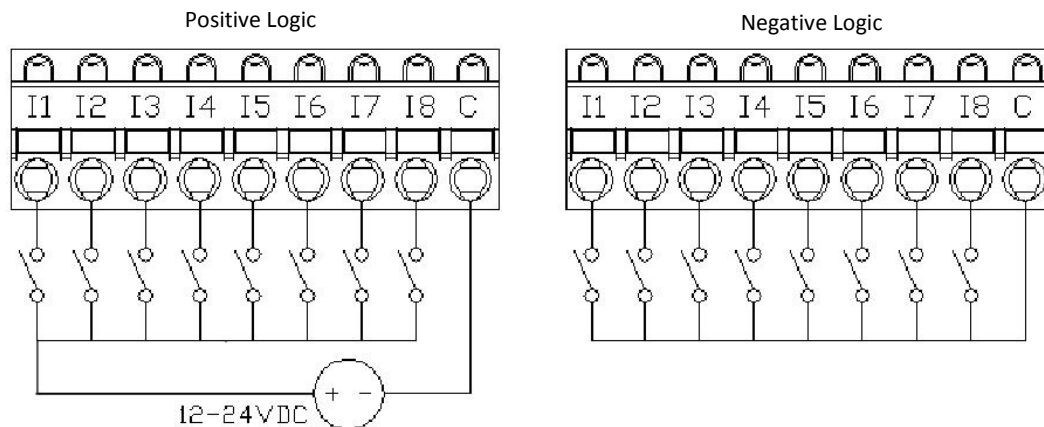

Figure 3 - HE57DIQ880/881 Inputs

#### 4. CONFIGURATION

For most applications, the I/O scanner built into Cscape and the OCS firmware will provide a fast, robust, and easy to use method to configure and scan the SmartBlock I/O. For advanced operations, such as on- the-fly changes to the input type, please see the following chapter on network data and the SmartStix and SmartBlock programming guide.

To configure SmartBlock I/O from Cscape open the Hardware Configuration dialog from the **Controller | Hardware Configuration** menu:

1. Select the option for **CsCAN I/O**.
2. Click Add. Select the **SmartBlock** Tab.
3. Select the device to be configured.

To the right is the configuration for the device and below are descriptions for the configuration data

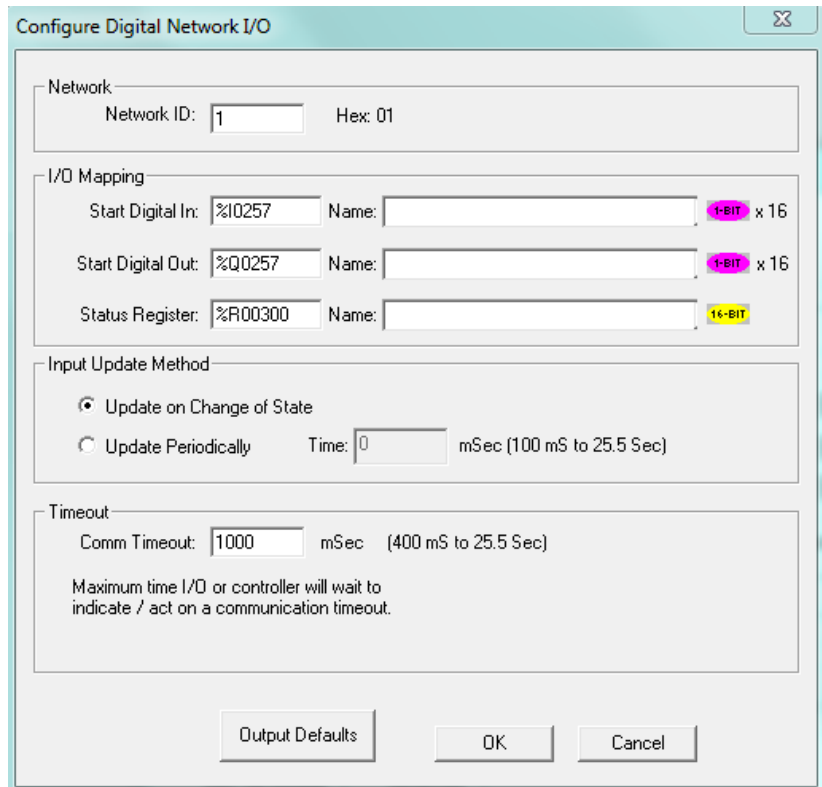

- **Network ID** – Should match the ID of the rotary switch on the SmartBlock unit and should be unique to the network.
- **I/O Mapping** – These registers define how the OCS controller registers are mapped to the data to and from the SmartBlock I/O. These registers do not have to match the I/O types typically used for I/O such as %AI, %Q - Any standard controller registers may be used such as %R, %T and %M.
- **Input Update Method** – Defines how often analog data is sent from the SmartBlock to the CsCAN network. Digital data is transmitted on change of state by default
- **Timeout** – Sets the time a controller will wait before assuming the host OCS is off-line.
- **Status:** The host controller reports a 16-bit word of status information for each module it accesses. See following table for definitions:

Status Word Definitions		
Bit	Status	Definition
0	N/A	Normal Operating Status
1	Offline	<b>TRUE</b> if no I/O device was found with the configured Network ID
2	No_Cfg	<b>TRUE</b> if the module is waiting to be configured by the Host Controller
3	Mismatch	<b>TRUE</b> if the attached device is something other than a SmartBlock I/O Module
4	Bad_FW	<b>TRUE</b> if the module's firmware is too old and therefore can't be accessed by the Host Controller
8-5	0	N/A
9	Life_Error	<b>TRUE</b> if the module detected loss of communication with the Host Controller, in which case the Module had set all its outputs to defaults. Can be cleared only by Controller
10	Pup_Error	<b>TRUE</b> if Module was reset and was reconfigured. Can be cleared only by Controller
15-11	0	N/A
16	Send_Now	An application can set the <b>Send_Now</b> bit to true, forcing all output data to be updated immediately. When all outputs are updated, the <b>Send_Now</b> bit is automatically cleared by the controller.

## 5. NETWORK DATA

**Consumed Digital Data** – This data is sent from the controller to the SmartBlock. For typical applications, the I/O configuration setup in Cscape will automatically populate this data. For more advanced applications, you may use NetPut functions to write this data. Please see the advanced programming guide **MAN0880** for more details.

Bit	Description	
1-8	Digital Outputs	Bits that control the relay or DC outputs
9-64	Reserved	
65-72	Output Hold	1 = Hold on stop, 0 = Override
73-79	Reserved	
80	Positive/Negative Inputs	0 = Positive Logic, 1 = Negative Logic
81-96	Reserved	
97-104	Output Override Data	Output on stop when hold = 0
105-120	Reserved	

**Produced Digital Data** – This data is sent from the SmartBlock to the controller. Normally this data is mapped into specific registers in the I/O configuration in Cscape. For advanced applications, NetGet functions can be used to obtain this data. Since this data is broadcasted to all controllers on the network, additional controllers can use NetGet functions to obtain this data as well.

Bit	Description	
1-8	Digital Inputs	Data from the digital inputs
9	HE579DIQ881	0 = OK, 1 = Fault on output channels 1-4
10	HE579DIQ881	0 = OK, 1 = Fault on output channels 5-8
11-32	Reserved	
33-48	Status & Diagnosis Data	
49-56	Firmware Version	
57-64	Device Class	2

## 6. SETTING ID SWITCHES

CsCAN Network IDs are set using the hexadecimal number system from 01 to FD. The decimal equivalents are whole numbers 1-253. Refer to following Conversion Table, which shows the decimal equivalent of hexadecimal numbers. Set a unique Network ID by inserting a small flat-bladed screwdriver into the two identical switches.

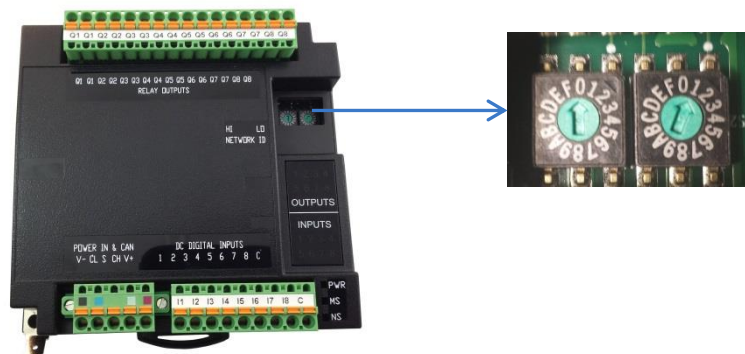

**NOTE:** The CsCAN Baud Rate for SmartBlock I/O is fixed at 125KBaud

## 7. LED INDICATORS

SmartBlock I/O Modules provide diagnostic and status LED indicators

Diagnostic LED Indicators		
Diagnostic LED	State	Meaning
<b>MS</b> indicates fault status of the Network	Solid Red	RAM or ROM test failed
	Blinking Red	I/O test failed
	Blinking Green	Module is in power-up state
	Solid Green	Module is running normally
<b>NS</b> Indicates fault status of the Network	Solid Red	Network Ack or Dup ID test failed
	Blinking Red	Network ID test failed
	Blinking Green	Module is in Life Expectancy default state
	Solid Green	Network is running normally

**Status LED indicators** – The Power Status LED illuminates **GREEN** when power is applied to the module. There are I/O status LED indicators for each of the Digital I/O points, which illuminate **GREEN** when the I/O point is ON.

## 8. INSTALLATION / SAFETY

**WARNING:** Remove power from the CAN port and any peripheral equipment connected to this local system before adding or replacing this or any module

All applicable codes and standards should be followed in the installation of this product.

When found on the product, the following symbols specify:



**WARNING:** Consult user documentation.



**WARNING:** Electrical Shock Hazard.

**WARNING:** To avoid the risk of electric shock or burns, always connect the safety (or earth) ground before making any other connections.

**WARNING:** To reduce the risk of fire, electrical shock, or physical injury it is strongly recommended to fuse the voltage measurement inputs. Be sure to locate fuses as close to the source as possible.

**WARNING:** Replace fuse with the same type and rating to provide protection against risk of fire and shock hazards.

**WARNING:** In the event of repeated failure, do not replace the fuse again as a repeated failure indicates a defective condition that will not clear by replacing the fuse.

**WARNING:** Only qualified electrical personnel familiar with the construction and operation of this equipment and the hazards involved should install, adjust, operate, or service this equipment. Read and understand this manual and other applicable manuals in their entirety before proceeding. Failure to observe this precaution could result in severe bodily injury or loss of life.

All applicable codes and standards need to be followed in the installation of this product.

For I/O wiring (discrete), use the following wire type or equivalent: Belden 9918, 18 AWG or larger.

Adhere to the following safety precautions whenever any type of connection is made to the module:

- Connect the green safety (earth) ground first before making any other connections.
- When connecting to electric circuits or pulse-initiating equipment, open their related breakers.
- Do not make connections to live power lines.
- Make connections to the module first; then connect to the circuit to be monitored.
- Route power wires in a safe manner in accordance with good practice and local codes.
- Wear proper personal protective equipment including safety glasses and insulated gloves when making connections to power circuits.
- Ensure hands, shoes, and floors are dry before making any connection to a power line.
- Make sure the unit is turned OFF before making connection to terminals. Make sure all circuits are de-energized before making connections.
- Before each use, inspect all cables for breaks or cracks in the insulation. Replace immediately if defective.

## 9. TECHNICAL SUPPORT

### North America

Tel: 1877-665-5666

Fax: 317 639-4279

Web: <http://www.hornerautomation.com>

Email: [techsppt@heapg.com](mailto:techsppt@heapg.com)

### Europe

Tel: +353-21-4321266

Fax: +353-21-4321826

Web: <http://www.horner-apg.com>

Email: [tech.support@horner-apg.co](mailto:tech.support@horner-apg.co)