



# XLE OCS Model: HE-XE102 / HEXE220C112 / HEXE220C012

## 12 Digital DC Inputs 4 Analog Inputs (Medium Resolution) 6 Digital Relay Outputs

**1 Specifications**

Specifications		
Digital DC Inputs		
Inputs per Module	12 including 4 configurable HSC inputs	
Commons per Module	1	
Input Voltage Range	12 VDC / 24 VDC	
Absolute Max. Voltage	35 VDC Max.	
Input Impedance	10 kΩ	
Input Current	<u>Positive Logic</u>	<u>Negative Logic</u>
Upper Threshold	0.8 mA	-1.6 mA
Lower Threshold	0.3 mA	-2.1 mA
Max Upper Threshold	8 VDC	
Min Lower Threshold	3 VDC	
OFF to ON Response	1 ms	
ON to OFF Response	1 ms	
HSC Max. Switching Rate	10 kHz Totalizer/Pulse, Edges 5 kHz Frequency/Pulse, Width 2.5 kHz Quadrature	
Digital Relay Outputs		
Outputs per Module	6 relay	
Commons per Module	6	
Max. Output Current per Relay	3 A at 250 VAC, resistive	
Max. Total Output Current	5 A continuous	
Max. Output Voltage	275 VAC , 30 VDC	
Max. Switched Power	1250 VA, 150 W	
Contact Isolation to XLe ground	1000 VAC	
Max. Voltage Drop at Rated Current	0.5 V	
Expected Life (See Derating section for chart.)	No load: 5,000,000 Rated load: 100,000	
Max. Switching Rate	300 CPM at no load 20 CPM at rated load	
Type	Mechanical Contact	
Response Time	One update per ladder scan plus 10 ms	
Analog Inputs, Medium Resolution		
Number of Channels	4	
Input Ranges	0 - 10 VDC 0 - 20 mA 4 - 20 mA	
Safe input voltage range	-0.5 V to +12V	
Input Impedance (Clamped @ -0.5 VDC to 12 VDC)	<u>Current Mode:</u> 100 Ω	<u>Voltage Mode:</u> 500 k Ω
Nominal Resolution	10 Bits	
%AI full scale	32,000 counts	
Max. Over-Current	35 mA	
Conversion Speed	All channels converted once per ladder scan	
Max. Error at 25°C (excluding zero) *can be made tighter (-0.25%) by adjusting the digital filter setting to 3.	4-20 mA 0-20 mA 0-10 VDC	1.00% 1.00% 1.50%*
Additional error for temperatures other than 25°C	TBD	
Filtering	160 Hz hash (noise) filter 1-128 scan digital running average filter	
General Specifications		
Required Power (Steady State)	130 mA @ 24 VDC	
-22 Low Temp Option	390mA with heater operating	
Required Power (Inrush)	30 A for 1 ms @ 24 VDC	
Primary Power Range	10 - 30 VDC	
Relative Humidity	5 to 95% Non-condensing	
Clock Accuracy	+/- Seven Minutes/Month at 20C	

General Specifications continued	
Operating Temperature	0°C to +50°C
-22 Low Temp Option	-40°C to +50°C
Terminal Type	Screw Type, 5 mm Removable
Weight	12 oz. (340.19 g)
CE	See Compliance Table at <a href="http://www.heapq.com/Pages/TechSupport/ProductCert.html">http://www.heapq.com/Pages/TechSupport/ProductCert.html</a>
UL	

**2 Panel Cut-Out and Dimensions**

Note: Max. panel thickness: 5 mm.

Refer to the XLe/XLt User Manual for panel box information and a handy checklist of requirements.  
**Note:** The tolerance to meet NEMA standards is ± 0.005" (0.1 mm).

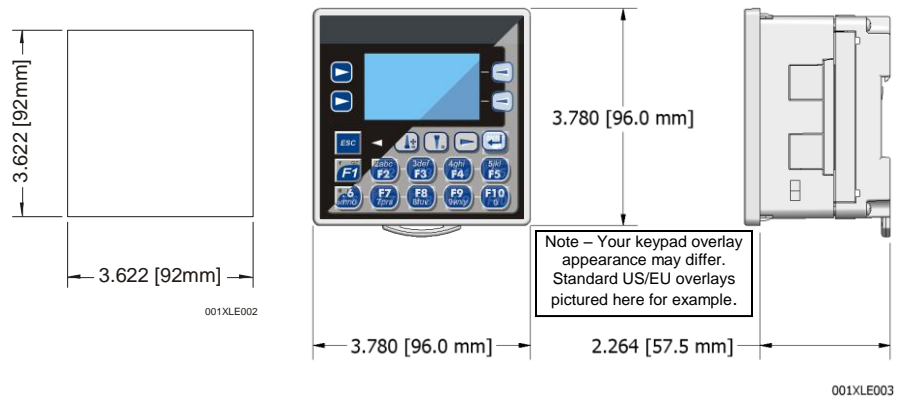

**3 Ports / Connectors / Cables**

**Note:** The case of the XLe is black, but for clarity, it is shown in a lighter gray color.

**To Remove Back Cover:**  
Unscrew 4 screws located on the back of the unit.  
Remove cover.

**CAUTION:** Do not over tighten screws when replacing the back cover.

**I/O Jumpers: (Not Shown):**  
I/O Jumpers (JP) are located internally. To access, remove back cover of unit.

**Wiring Connectors (J1 / J2):**  
I/O Jumpers (JP1 / JP2), and External Jumpers (RS-485) are described in the **Wiring and Jumpers** section of this document.

**Memory Slot:**  
Uses **Removable Memory** for data logging, screen captures, program loading and recipes.  
**Horner Part No.: HE-MC1**

**Serial Communications:**  
**MJ1:** (RS-232 / RS-485) Use for Cscape programming and Application-Defined Communications.  
**MJ2:** (RS-232 / RS-485) Use for Application-Defined Communications.

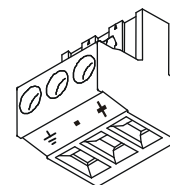
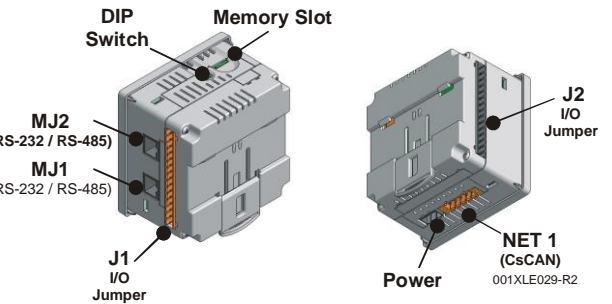

**Power Connector**

**Power Up:**  
Connect to Earth Ground.  
Apply 10 - 30 VDC.  
Screen lights up.

Torque rating 4.5 - 7 Lb-In (0.50 - 0.78 N-m)

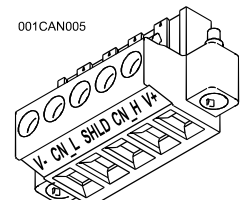

**CAN Connector**

Use the CAN Connector when using CsCAN network.

Torque Rating 4.5 - 7 Lb-In (0.50 - 0.78 N-m)

4 Serial Communications:

**MJ1:** (RS-232 / RS-485) Use for Escape programming and Application-Defined Communications.

**MJ2:** (RS-232 / RS-485) Use for Application-Defined Communications.

Pin	MJ1 Pins		MJ2 Pins	
	Signal	Direction	Signal	Direction
8	TXD	OUT	TXD	OUT
7	RXD	IN	RXD	IN
6	0 V	Ground	0 V	Ground
5*	+5 60mA	OUT	+5 60mA	OUT
4	RTS	OUT	TX-	OUT
3	CTS	IN	TX+	OUT
2	RX- / TX-	IN / OUT	RX-	IN
1	RX+ / TX+	IN / OUT	RX+	IN

\* +5 on XLe Rev E and later

5 Wiring and Jumpers

Wire according to the type of inputs / outputs used, and select the appropriate jumper option.

Wiring Specifications

•For I/O wiring (discrete), use the following wire type or equivalent: Belden 9918, 18 AWG (0.8 mm<sup>2</sup>) or larger.

•For shielded Analog I/O wiring, use the following wire type or equivalent: Belden 8441, 18 AWG (0.8 mm<sup>2</sup>) or larger.

•For CAN wiring, use the following wire type or equivalent: Belden 3084, 24 AWG (0.2 mm<sup>2</sup>) or larger.

Use copper conductors in field

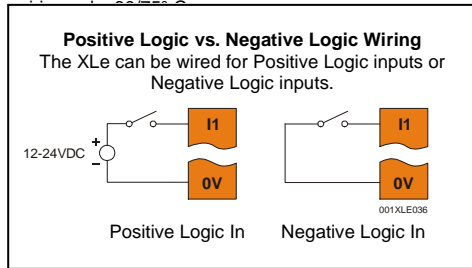
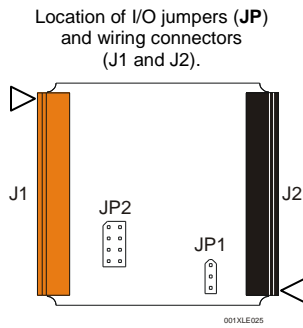

5.1 Wiring Examples

J1 Orange Terminal Connector	Name
I1	IN1
I2	IN2
I3	IN3
I4	IN4
I5	IN5
I6	IN6
I7	IN7
I8	IN8
H1	HSC1 / IN9
0V	Ground
A1	Analog IN1
A2	Analog IN2
A3	Analog IN3
A4	Analog IN4
0V	Ground

**Note:** Loop Power requirements are determined by the transmitter specification.

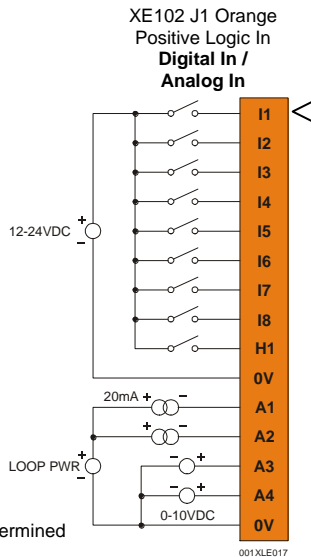

5.2 Wiring Examples (continued)

J2 Black Terminal Connector	Name
C6	Relay 6 COM
R6	Relay 6 NO
C5	Relay 5 COM
R5	Relay 5 NO
C4	Relay 4 COM
R4	Relay 4 NO
C3	Relay 3 COM
R3	Relay 3 NO
C2	Relay 2 COM
R2	Relay 2 NO
C1	Relay 1 COM
R1	Relay 1 NO
H4	HSC4 / IN12
H3	HSC3 / IN11
H2	HSC2 / IN10

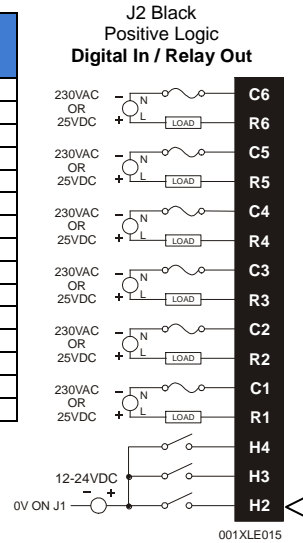

5.3 I/O Jumpers Settings (JP1 - JP2)

JP1 Digital DC In / HSC

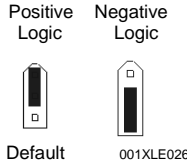

JP2 Analog In (A1 - A4)

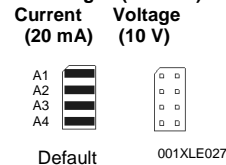

**Note:** The Cscape Module Setup configuration must match the selected I/O (JP) jumper settings.

**Note:** When using JP2 (A1-A4), each channel can be independently configured.

5.4 External DIP Switch Settings (or Jumpers Settings)

Some XLes have jumpers to set RS-485 port termination, though most use DIP Switches.

The External Jumpers or DIP Switches are used for termination of the RS-485 ports. The XLe is shipped un-terminated.

To terminate, select one of the jumpers shipped with the product and insert it based upon the option that is desired or, select the switch and configure based upon the option that is desired.

**Note:** A common cause of Analog Input Transorb Failure on Analog Inputs Model 2, 3, 4 & 5: If a 4-20mA circuit is initially wired with loop power, but without a load, the Analog input could see 24Vdc. This is higher than the rating of the transorb. This can be solved by NOT connecting loop power prior to load connection, or by installing a low-cost PTC in series between the load and Analog input.

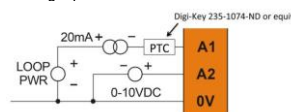

As seen when looking at the top of the XLe unit: Refer to Section 3 for the location of the DIP Switches (or External Jumpers).

DIPSW3: FACTORY USE ONLY (tiny bootloader firmware downloading). NOT TO BE USED FOR NORMAL OCS OPERATION.  
DIPSW2: MJ2 Termination (Default - none)  
DIPSW1: MJ1 Termination (Default - none)

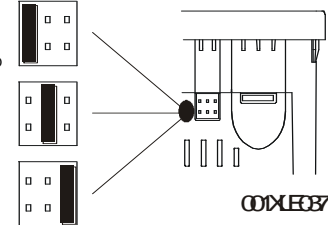

DIPSW3: FACTORY USE ONLY (tiny bootloader firmware downloading). NOT TO BE USED FOR NORMAL OCS OPERATION.  
DIPSW2: MJ2 Termination (Default - none)  
DIPSW1: MJ1 Termination (Default - none)

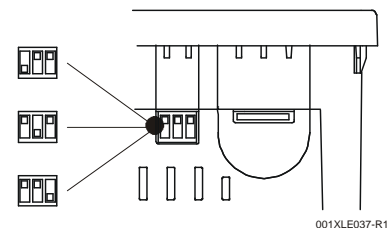

6 MJ2 Pinouts in Full and Half Duplex Modes

Pin	MJ2 Pins	
	Signal	Direction
8	TXD	OUT
7	RXD	IN
6	0 V	Ground
5*	+5 60mA	OUT
4	TX-	OUT
3	TX+	OUT
2	RX-	IN
1	RX+	IN

\* +5 on XLe Rev E and later

MJ2 Full Duplex Mode

Pin	MJ2 Pins	
	Signal	Direction
8	TXD	OUT
7	RXD	IN
6	0 V	Ground
5*	+5 60mA	OUT
4	TX-	OUT
3	TX+	OUT
2	TX-/RX-	IN/OUT
1	TX+/RX+	IN/OUT

\* +5 on XLe Rev E and later

MJ2 Half Duplex Mode

7. Filter

Filter Constant sets the level of digital filtering according to the following chart.

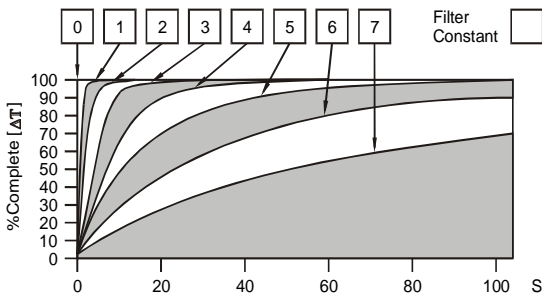

**Digital Filtering.** The illustration above demonstrates the effect of digital filtering (set with Filter Constant) on module response to a temperature change.

8 Derating

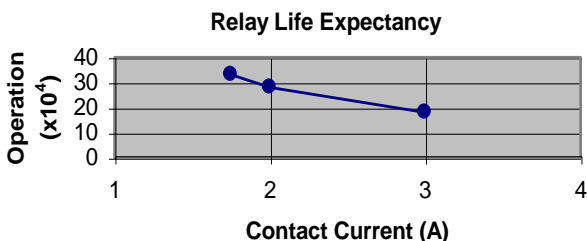

9 I/O Register Map

Registers	Description
%I1 to %I24	Digital Inputs
%I32	Output Fault
%I25 to %I31	Reserved
%Q1 to %Q16	Digital outputs
%Q17	Clear HSC1 accumulator to 0
%Q18	Totalizer: Clear HSC2
%Q19	Quadrature 1-2: Accumulator 1 Reset to max – 1
%Q20	Clear HSC3 Accumulator to 0
%Q21	Totalizer: Clear HSC4
%Q22	Quadrature 3-4: Accumulator 3 Reset to max – 1
%Q21 to %Q32	Reserved
%A1 to %A14	Analog inputs
%A15, %A16	HSC1 Accumulator
%A17, %A18	HSC2 Accumulator
%A19, %A110	HSC3 Accumulator
%A111, %A112	HSC4 Accumulator
%AQ1, %AQ2	PWM1 Duty Cycle
%AQ3, %AQ4	PWM2 Duty Cycle
%AQ5, %AQ6	PWM Prescale
%AQ7, %AQ8	PWM Period
%AQ9 to %AQ14	Analog outputs

**Note:** Not all XLe units contain the I/O listed in this table.

10 Safety

When found on the product, the following symbols specify:

**Warning:** Electrical Shock Hazard.
 
**Warning:** Consult user documentation.

This equipment is suitable for use in Class I, Division 2, Groups A, B, C and D or Non-hazardous locations only

**WARNING – EXPLOSION HAZARD** – Substitution of components may impair suitability for Class I, Division 2

**AVERTISSEMENT - RISQUE D'EXPLOSION** - LA SUBSTITUTION DE COMPOSANTS PEUT RENDRE CE MATERIAL INACCEPTABLE POUR LES EMBLEMES DE CLASSE 1, DIVISION 2

**WARNING – EXPLOSION HAZARD** – Do not disconnect equipment unless power has been switched off or the area is known to be non-hazardous.

**AVERTISSEMENT - RISQUE D'EXPLOSION** - AVANT DE DECONNECTER L'EQUIPMENT, COUPER LE COURANT OU S'ASSURER QUE L'EMPLACEMENT EST DESIGNÉ NON DANGEREUX.

**WARNING:** To avoid the risk of electric shock or burns, always connect the safety (or earth) ground before making any other connections.

**WARNING:** To reduce the risk of fire, electrical shock, or physical injury it is strongly recommended to fuse the voltage measurement inputs. Be sure to locate fuses as close to the source as possible.

**WARNING:** Replace fuse with the same type and rating to provide protection against risk of fire and shock hazards.

**WARNING:** In the event of repeated failure, do not replace the fuse again as a repeated failure indicates a defective condition that will not clear by replacing the fuse.

**WARNING:** Only qualified electrical personnel familiar with the construction and operation of this equipment and the hazards involved should install, adjust, operate, or service this equipment. Read and understand this manual and other applicable manuals in their entirety before proceeding. Failure to observe this precaution could result in severe bodily injury or loss of life.

This device complies with part 15 of the FCC Rules. Operation is subject to the following two conditions:

1. This device may not cause harmful interference.
2. This device must accept any interference received, including interference that may cause undesired operation.

- All applicable codes and standards need to be followed in the installation of this product.
- Adhere to the following safety precautions whenever any type of connection is made to the module:

- Connect the safety (earth) ground on the power connector first before making any other connections.
- When connecting to electric circuits or pulse-initiating equipment, open their related breakers.
- Do not make connections to live power lines.
- Make connections to the module first; then connect to the circuit to be monitored.
- Route power wires in a safe manner in accordance with good practice and local codes.
- Wear proper personal protective equipment including safety glasses and insulated gloves when making connections to power circuits.
- Ensure hands, shoes, and floors are dry before making any connection to a power line.
- Make sure the unit is turned OFF before making connection to terminals.
- Make sure all circuits are de-energized before making connections.
- Before each use, inspect all cables for breaks or cracks in the insulation. Replace immediately if defective.
- Use Copper Conductors in Field Wiring Only, 60/75° C

## 11 Technical Support

For assistance and manual updates, contact Technical Support at the following locations:

**North America:**

(317) 916-4274

[www.heapg.com](http://www.heapg.com)

email: [techsppt@heapg.com](mailto:techsppt@heapg.com)

**Europe:**

(+) 353-21-4321-266

[www.horner-apg.com](http://www.horner-apg.com)

email: [techsupport@hornerirl.ie](mailto:techsupport@hornerirl.ie)

**"WARNING: EXPOSURE TO SOME CHEMICALS MAY DEGRADE THE SEALING PROPERTIES OF MATERIALS USED IN THE Tyco relay PCJ**

Cover / case & base: Mitsubishi engineering Plastics Corp.  
5010GN6-30 or 5010GN6-30 M8 (PBT)  
Sealing Material: Kishimoto 4616-50K (I part epoxy resin)

*It is recommended to periodically inspect the relay for any degradation of properties and replace if degradation is found*

No part of this publication may be reproduced without the prior agreement and written permission of Horner APG, Inc. Information in this document is subject to change without notice.