



## P900

### SPECIFICATIONS

- **Field proven rugged construction**
- **High overpressure capability**
- **High reliability for demanding environments**
- **Application specific customization**
- **Excellent media compatibility**
- **Shock and vibration resistant**

P900 Series Strain Gauge Pressure Transducers are premium grade sensors that provide highly precise measurement of absolute, vented gauge, or sealed gauge pressures over wide temperature ranges. Standard versions of this transducer use a 17-4 PH stainless steel diaphragm to sense pressure (Inconel versions are available for operation in highly corrosive environments). The deflection of the diaphragm is transferred to a double cantilever beam by a force transfer rod. Strain in the beam, and therefore, input pressure is measured by four foil strain gauges. An all-welded construction provides high reliability and stability. Capable of sensing extremely small changes of applied pressure, the transducers are relatively insensitive to vibration, attitude, and shock. The P900 Series Pressure Sensors are available in a range of electrical inputs and outputs. Zero and span potentiometers are available as a special option with the P940, P950, P960, and P990 models. Non-standard pressure ranges are available in all models of the P900 Series.

For parts requiring RoHS compliance, please contact factory.

**FEATURES**

- High Overload capability
- Operation in High Temperatures
- Shock and Vibration Resistant
- 2-wire, 4-20 mA option; Intrinsic Safety Approval to E Exia IIC T4 (Tamb=60°C) BASEEFA, CENELEC EN50-020

**APPLICATIONS**

- Hydraulic Pressure Monitoring
- Torpedo Depth Sensing
- Vehicle Brake System Monitoring
- Military and Commercial Aircraft

**PERFORMANCE SPECS**

Series	P900	P910	P940	P950	P960	P970	P980	P990
<b>Model Number</b>	P901/904	P911/4	P941/4	P951/4	P961/4	P971/4	P981/4	P991/4
<b>Input Voltage</b>	10VDC (12 V max)	10VDC (12 V max)	10VDC	11-18VDC	18-32VDC	15-36VDC	10-36VDC	±15VDC
<b>Current Consumption(mA)</b>	13	30	20	20	20	20	-	20
<b>Full Range Output (±1%)</b>	20mV	20mV	5VDC	2.5VDC	5VDC	10VDC	4-20mA	5VDC
<b>Impedance (ohm)</b>	1000 ±5%	350	<10	<10	<10	<10	Load Resist. 1300 max. at 36VDC	<10
<b>Current (mA max)</b>	-	-	5	5	5	5	-	5
<b>Frequency Response</b>	Approx. 2.5 kHz to 40 kHz for .7 bar	Approx. 2.5 kHz to 40 kHz for .7 bar	1 kHz	1 kHz	1 kHz	1 kHz	100 Hz	1 kHz
<b>Combined Thermal – Zero &amp; Sensitivity Shift</b>								
<b>% F.R.O./°F</b>	±0.008	-	±0.008	±0.008	±0.008	±0.008	±0.008	±0.008
<b>% F.R.O./°C</b>	±0.015	±0.007	±0.015	±0.015	±0.015	±0.015	±0.015	±0.015
<b>Residual Unbalance</b>								
<b>% F.R.O.</b>	±1	±1	±1	±1	±1	±1	±1	±1
<b>Weight oz (gm)</b>								
<b>Connector Version</b>	4.4 (125)	4.4 (125)	5.1 (145)	5.1 (145)	5.1 (145)	5.1 (145)	5.1 (145)	5.1 (145)
<b>Cable Version</b>	5.6 (160)	5.6 (160)	6.3 (180)	6.3 (180)	6.3 (180)	6.3 (180)	6.3 (180)	6.3 (180)

## COMMON SPECIFICATIONS

### Pressure Ranges

<b>High (psi)</b>	0-75, 100, 150, 200, 250, 350, 500, 750, 1000, 1500, 2200, 3500, 5000, 7500, 10,000
<b>(bar)</b>	0-5, 7, 10, 15, 25, 35, 50, 70, 100, 150, 200, 250, 350, 500, 700
<b>Medium (psi)</b>	0-10, 15, 20, 25, 35
<b>(bar)</b>	0-0.7, 1.0, 1.5, 1.7, 2.5
<b>DIN (bar)</b>	1, 1.6, 2.5, 4, 6, 10, 16, 25, 40, 60, 100, 160, 250, 400, 600

### Pressure References

<b>High Pressure Range</b>	Vented gauge 1: 0-75 to 0-350 psi Absolute and sealed gauge: 0-75 to 0-10,000 psi
<b>Medium Pressure Range</b>	Vented gauge <sup>1</sup> and absolute: 0-10, 15, 20, 25, 35 psi (0-0.7, 1.0, 1.5, 1.7, 2.5 bar)
<b>Pressure Limit</b>	5x full range pressure or 12,000 psi (830 bar), whichever is less. Will not cause a zero offset exceeding 0.04% FRO (recoverable within a few hours)
<b>Burst Pressure</b>	20 x full range pressure or 22,000 psi (1,520 bar), whichever is less
<b>Pressure Media</b>	Liquids or gases compatible with 17-4 PH and 17-7 PH stainless steel or Inconel 625
<b>Shunt Calibration</b>	80% ±5% full range pressure (not fitted in P980 Series)
<b>Combined Non-linearity, Hysteresis and Non-repeatability</b>	High Range: <±0.10% F.R.O. (BSL); Medium Range: <±0.20% F.R.O. (BSL)
<b>Temperature Range</b>	
<b>Operable</b>	-65°F to 250°F (-54°C to 120°C) <b>P91X</b> : -65°F to 300°F (-54°C to 150°C)
<b>Compensated</b>	32°F to 212°F (0°C to 100°C) <b>P91X</b> : -65°F to 250°F (-54°C to 120°C) or -4°F to 176°F (-20°C to +80°C)
<b>Storage</b>	-65°F to 300°F (-54°C to 150°C)
<b>Humidity</b>	
<b>Connector Version</b>	95% Relative humidity
<b>Cable Version</b>	Immersible to IP67 (fluid must not enter the ends of the cable)
<b>Acceleration Response</b>	Above 500 psi (35 bar) ±0.02% F.R.O./g; below 500 psi (35 bar) ±0.10% F.R.O./g
<b>Vibration</b>	Surpasses MIL STD810C Method 514-2 Curve L and EUROCAE ED 14A/RTCA 160A
<b>Shock</b>	1000 g for 5 msec will not damage the sensor
<b>EMC</b>	The P940, P950, P960 and P980 and P990 Series are CE marked, and when correctly installed comply with the EMC Directive 89/336/EEC Generic Standards for Residential Commercial, Light Industrial and Industrial environments. Note: The P980 Series when used in Intrinsic Safety applications does not comply with the Industrial environment directive.
<b>Insulation Resistance</b>	500 MOhm at 50 VDC at 25°C

<sup>1</sup> Vented gauge units must only be used in dry, noncorrosive environments and will breathe through the cable vent tube or hole in the 6-way receptacle.

<b>Total Thermal Error Band (P91X only)</b>	-20°C to +80°C	<±0.4% FRO Typical, <±0.6% FRO Maximum
	-54°C to +120°C	<±0.7% FRO Typical, <±1.0% FRO Maximum

DIMENSIONS

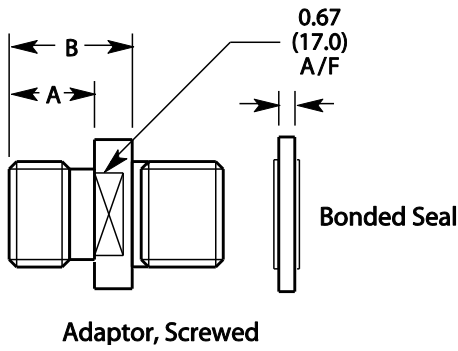
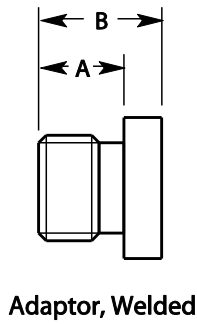
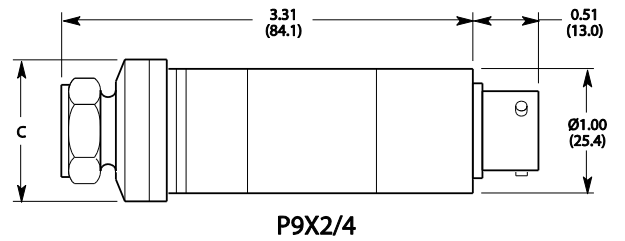
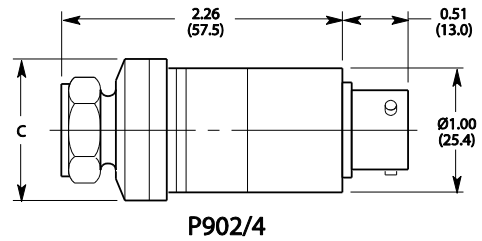
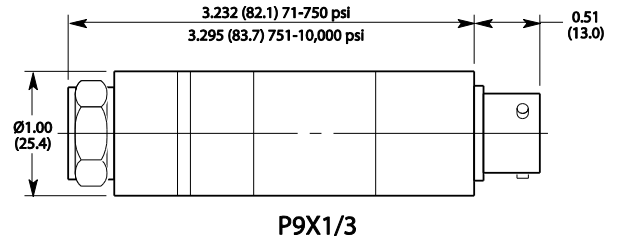
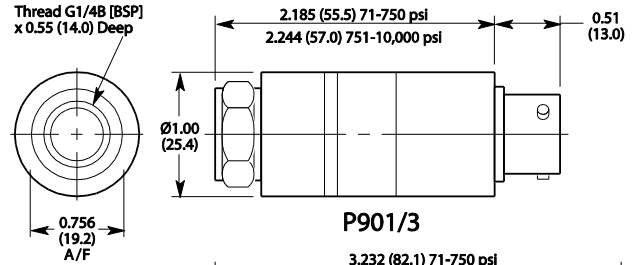
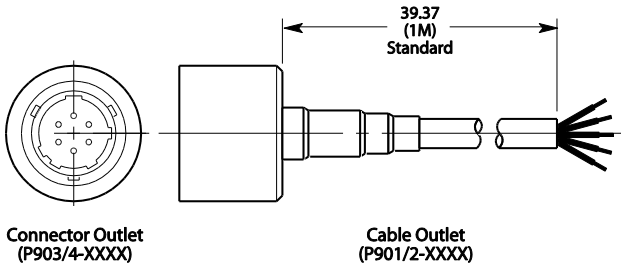

Connector:  
MIL-C-26482,  
Shell Size 10, 6 PIN

## ADAPTERS

Code Thread Size	Dimensions in (mm)		
	Welded	A	B 1/4" BSP (F)
G1/4A (BSP) (M)	0002	0.46 (11.7)	0.67 (16.9)
M14 x 1.5 (M)	0003	0.40 (10.2)	0.61 (15.4)
7/16"-20UNF-2A (M)	0004	0.56 (14.3)	0.77 (19.5)
1/4"-18NPT (M)	0005	0.55 (14.0)	0.76 (19.2)
M10 x 1.0 (F)	0006	—	0.60 (15.2)
1/4-18NPT (F)	0009	—	0.76 (19.2)
Thread Size	Screwed	A	B
G1/4A (BSP) (M)	0022	0.46 (11.7)	0.70 (17.8)
M14 x 1.5 (M)	0023	0.40 (10.2)	0.62 (15.8)
7/16"-20UNF-2A (M)	0024	0.56 (14.3)	0.78 (19.8)
1/4"-18NPT (M)	0025	0.55 (14.0)	0.80 (20.4)
M10 x 1.0 (M)	0026	—	0.60 (15.2)
Range	Diameter C in (mm)		
10 psi (0.7 bar)	1.143 (29.05)		
15 psi (1.0 bar)	1.043 (26.50)		
20 psi (1.5 bar)	0.888 (22.50)		
25 psi (1.7 bar)	0.807 (20.50)		
35 psi (2.5 bar)	0.748 (19.00)		

## CONNECTIONS

Cable	Connector <sup>2</sup>
Red <sup>1</sup>	Pin A <sup>1</sup> Excitation (+)
White	Pin D Excitation (-) <sup>3</sup>
Yellow	Pin B Output (+)
Blue <sup>1,3</sup>	Pin C <sup>1,2</sup> Output (-) <sup>3</sup>
Violet	Pin E } 80% shunt calibration <sup>4</sup>
Grey	Pin F }

**Note:** Screen is connected to the case for CE marked units.  
Screen is not connected to the case for optional IS units (P980).  
IS certification revokes CE certification.

- 2-wire transmitter connections
- Vented gauge units must breathe through the receptacle (mating connector must have a vent hole)
- 0 Volt P990 series
- Connected internally for P940, P950, P960 Series (3-wire)
- Shunt calibration not fitted to P980 Series

### Connector Orientation

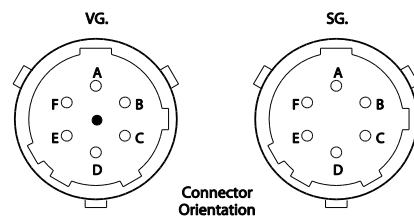

WIRING

P901/9, P910/9

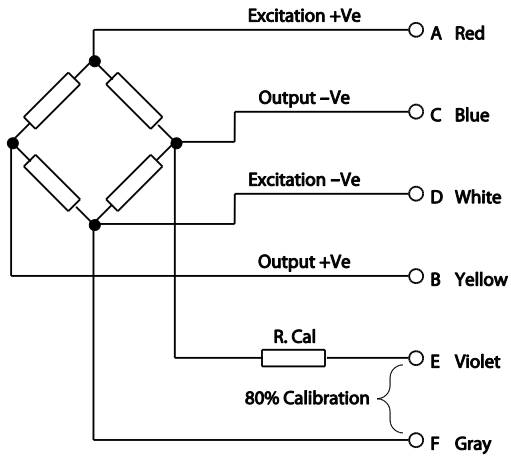

P991/9

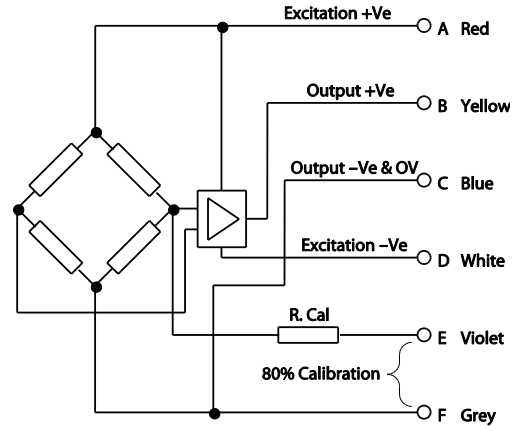

P981/9

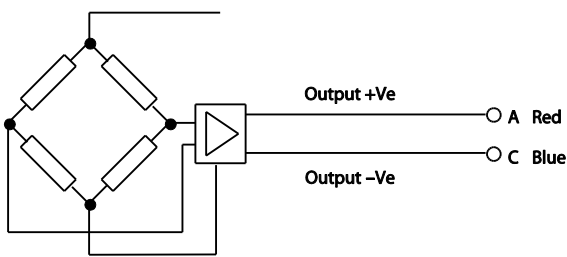

P941/9, P951/9, P961/9, P971/9

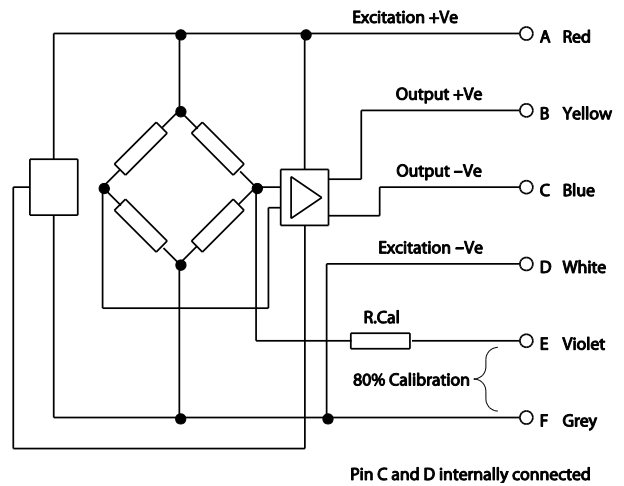

ORDERING INFORMATION

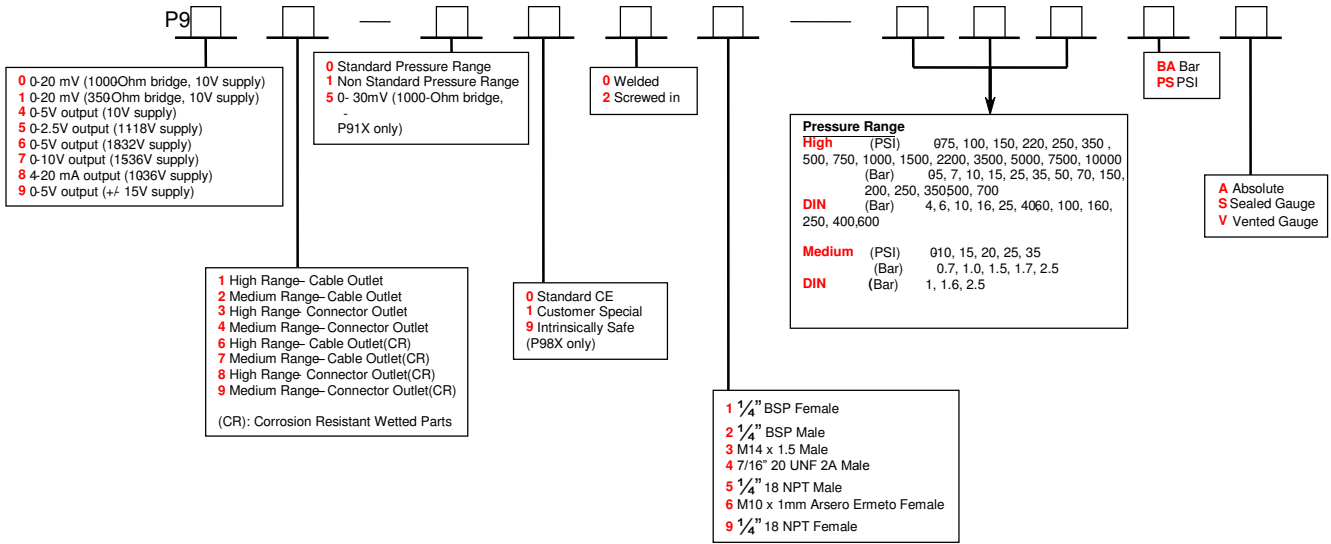

**NOTE:** Unit comes standard with 1 meter of cable.

For a different cable length, add 2 digits "xx" to the end of the configuration above indicating the length desired. Max 20 meters.

**NORTH AMERICA**

Measurement Specialties, Inc.,  
 a TE Connectivity company  
 45738 Northport Loop West  
 Fremont, CA 94538  
 Tel: +1 800 767 1888  
 Fax: +1 510 498 1578  
[customercare.frmt@te.com](mailto:customercare.frmt@te.com)

**EUROPE**

MEAS France SAS,  
 a TE Connectivity company  
 4 Rue Gaye Marie  
 31027 Toulouse, France  
 Tel: +33 (5) 822 822 00  
 Fax: +33 (5) 820 821 51  
[customercare.tlse@te.com](mailto:customercare.tlse@te.com)

**ASIA**

Measurement Specialties (China) Ltd.,  
 a TE Connectivity company  
 No. 26 Langshan Road  
 Shenzhen High-Tech Park (North) Nanshan District,  
 Shenzhen, 518057  
 China  
 Tel: +86 755 3330 5088  
 Fax: +86 755 3330 5099  
[customercare.shzn@te.com](mailto:customercare.shzn@te.com)

**TE.com/sensorsolutions**

Measurement Specialties, Inc., a TE Connectivity company.

Measurement Specialties, TE Connectivity, TE Connectivity (logo) and EVERY CONNECTION COUNTS are trademarks. All other logos, products and/or company names referred to herein might be trademarks of their respective owners.

The information given herein, including drawings, illustrations and schematics which are intended for illustration purposes only, is believed to be reliable. However, TE Connectivity makes no warranties as to its accuracy or completeness and disclaims any liability in connection with its use. TE Connectivity's obligations shall only be as set forth in TE Connectivity's Standard Terms and Conditions of Sale for this product and in no case will TE Connectivity be liable for any incidental, indirect or consequential damages arising out of the sale, resale, use or misuse of the product. Users of TE Connectivity products should make their own evaluation to determine the suitability of each such product for the specific application.

© 2015 TE Connectivity Ltd. family of companies All Rights Reserved.