



Eliminates
Management
Of calibration
Data



Preliminary Technical Data*

FEATURES AND BENEFITS

IdentiCal™ Interchangeable Sensor

IdentiCal™ sensors eliminate the management of calibration data and allow convenient

interchangeability of individual sensors.

With standardized sensitivity and offset, there is no need to enter new parameters for each unit. 13203CC is perfect for high volume use.

Rugged for Harsh Environments

The 13203CC is robust to perform well in harsh environments. The 6061-T6 case with electroless nickel finish plus a PTFE cable with a shield bonded to the case provide improved resistance to EMI, lightning, or other disturbances. The enclosure is rated IP65. The unit has resilient power and will survive 5000 g powered and unpowered. The 13203CC has a 22 AWG cable with only four wires to connect.

High Accuracy and Linearity over Wide Temperature Range

The output of the 13203CC is directly proportional to the acceleration of its axis. The DC-coupled output is fully scaled, referenced, and temperature compensated. When used in demanding temperature environments, the 13203CC is one of the most accurate accelerometers available.

13203CC

SPECIFICATIONS

**Interchangeable, Rugged
Uniaxial Accelerometer ± 1 g to ± 15 g**

Precisely Measure Rates over Temperature.

The Measurement Specialties 13203CC is an interchangeable and rugged uniaxial accelerometer capable of accurately measuring acceleration under demanding environmental conditions. A tough, compact housing holds potted electronics and a shielded heavyweight cable.

Its cubical form allows mounting with the sensing axis oriented in any direction.

The 13203CC provides enhanced accuracy and durability features to meet the challenges of your application. In addition to its robust construction, increased precision is achieved through improved offset and gain compensation

Each axial sensor has been tested over the -40 to $+85^{\circ}\text{C}$ temperature range and has a nominal full scale output swing of ± 2 Volts. Sensors are available in various fixed sensitivities, each with a 2.500 V offset. The 13203CC can also be ordered with different bandwidths and wiring configurations.

Small Size

Complete conditioned accelerometer package in less than a cubic inch; it may be easily mounted for any axis orientation.

-Built-In Power Supply Regulation

Unregulated DC power from +8.5 to +36 Volts is all that is required to measure acceleration. The 13203CC is operational with transients of +80 V for 550 ms compatible with MIL-STD-704A.

Earth Friendly Design

Lead-free design makes the 13203CC environmentally safe while Measurement Specialties' assembly process ensures reliable functionality. Fully potted electronics eliminates the possibility of tin whiskers-related failures.

Three Year Warranty

These Measurement Specialties' accelerometers are covered by a three year return to factory warranty. Extended warranties are available.

SPECIFICATIONS FOR 13203CC - improved specifications available upon request

T_a = T_{min} to T_{max}; 8.5 ≤ V_s ≤ 36 V; Acceleration = 0 g unless otherwise noted; within one year of calibration.

Parameter	Min	Typical	Max	Units	Conditions/Notes
Range & Sensitivity* at 25°C					Must specify via Option Rnnn, see Ordering Info
Option R015		0.130		V/g	
Option R010		0.200		V/g	
Option R006		0.330		V/g	
Option R005		0.400		V/g	
Option R004		0.500		V/g	Maximum error ±0.75% of nominal at 25°C.
Option R003		0.660		V/g	
Option R002		1.000		V/g	
Option R001		2.000		V/g	
Sensitivity Drift 25°C to T _{min} or T _{max}		±1.0		% FSR	
Offset at 25°C Zero g Bias Level		2.50 ±0.015		V	Max error ±50 mg of nominal at 25°C
Offset Drift 25°C to T _{min} or T _{max}		±1.0		% FSR	
Alignment Deviation from Ideal Axes		±1.5		degrees	
Transverse Sensitivity		0.25		%	Inherent sensor error, excluding misalignment
Nonlinearity		0.10		% FSR	Best fit straight line
Frequency Response	0		800	Hz	Upper cutoff per Option Bnnn, -3dB pt ±10%
Noise Density		100		µg/√Hz	T _a = 25°C
Outputs					Measuring equipment >10 MΩ recommended
Output Voltage Swing	0.50		4.50	V	I _{out} = 1 mA, Capacitive load <1000 pF
Power Supply (V_s)					
Input Voltage Limits	-80		+80	V	-80V continuous, >38 V if ≤550 ms, duty <1%
Input Voltage - Operating	+8.5		+36	V	
Input Current		12		mA	No load, quiescent
Rejection Ratio		>120		dB	DC
Temperature Range (T_a)	-40		+85	°C	
Mass		38		grams	
Shock Survival	-5000		+5000	g	Any axis for 0.5 ms, powered or unpowered

Data subject to change without notice

*IdentiCal sensors are interchangeable, any with same range have same value

MECHANICAL

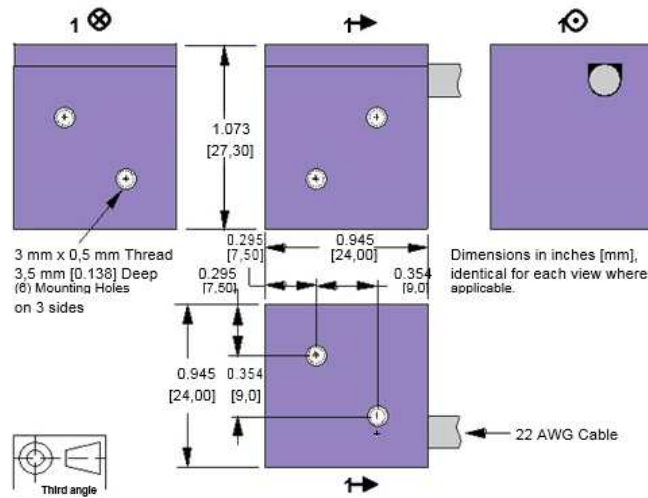

6061-T6 aluminum case with electroless nickel finish plus integrated cable with shield bonded at the case

Shown with
34170B
Mounting
Adapter
(Sold separately)

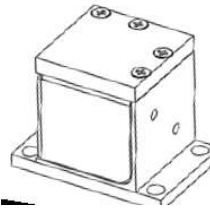

CONNECTIONS

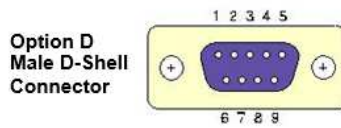

Pin	1	2	3	4	5	6	7	8	9
Signal	A1+	Signal -	Not	Not	Not	Not	Not	+Vs	Gnd
Wire	Green	Blue	Used	Used	Used	Used	Used	Orange	White

ORDERING INFORMATION

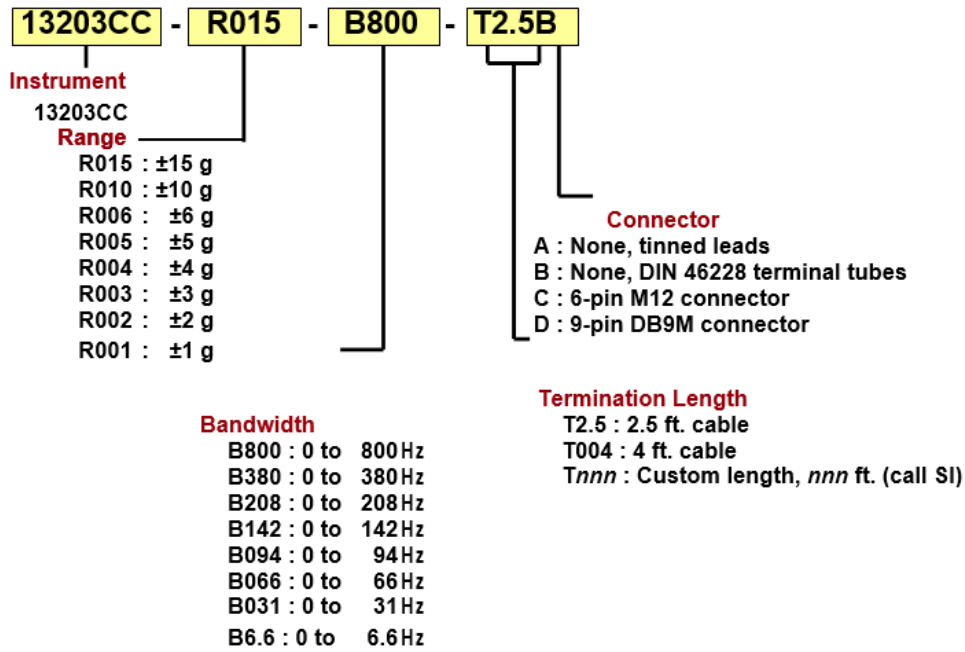

NORTH AMERICA

Measurement Specialties, Inc.,
a TE Connectivity Company
2236 N. Cleveland-Massillon Road
Akron, OH 44333
USA
Tel: +1-330-659-3312
Sales: pvg.cs.amer@meas-spec.com

EUROPE

MEAS France SAS
a TE Connectivity Company
26 Rue des Dames
F78340 Les Clayes-sous-Bois
France
Tel: +33 (0) 130 79 33 00
Fax: +33(0) 134 81 03 59
Sales: pfg.cs.emea@meas-spec.com

ASIA

Measurement Specialties (China), Ltd.,
a TE Connectivity Company
No. 26 Langshan Road
Shenzhen High-Tech Park (North)
Nanshan District, Shenzhen 518057
China
Tel: +86 755 3330 5088
Fax: +86 755 3330 5099
Sales: pfg.cs.asia@meas-spec.com

TE.com/sensorsolutions

Measurement Specialties, Inc., a TE Connectivity company.

Measurement Specialties, TE Connectivity, TE Connectivity (logo) and EVERY CONNECTION COUNTS are trademarks. All other logos, products and/or company names referred to herein might be trademarks of their respective owners.

The information given herein, including drawings, illustrations and schematics which are intended for illustration purposes only, is believed to be reliable. However, TE Connectivity makes no warranties as to its accuracy or completeness and disclaims any liability in connection with its use. TE Connectivity's obligations shall only be as set forth in TE Connectivity's Standard Terms and Conditions of Sale for this product and in no case will TE Connectivity be liable for any incidental, indirect or consequential damages arising out of the sale, resale, use or misuse of the product. Users of TE Connectivity products should make their own evaluation to determine the suitability of each such product for the specific application.

© 2015 TE Connectivity Ltd. family of companies All Rights Reserved.