



LS309-51N

LS Series–Level Sensor

Features

- High or low level sensing
- Internal or external fitting
- Reed Switch reliability
- Nitrile sealing washer/grommet
- Easy installation

Applications

- Chemical high or low level
- Diesel Fuel
- Fuel low level
- Alcohols
- Low Oil Detection

Comments

- Normally open or normally closed by rotating through 180
- Suitable for a wide range of liquids
- Interface option available
- Nylon 6.6 Material

Material

Housing Material	Glass Filled Nylon 6.6
Float Material	Glass Filled Nylon 6.6
Contact Material	Ruthenium
Float SG	0.85
Operating Temperature °C	-30 to 130
Medium	Fuels, Oils, Alcohols
Housing and Float Color	Blue

Cable

Cable Length	2 x 0.5M single insulated
Connection Type	Stripped Cables
Cable Type	18AWG, 32/0.2mm PVC insulated
Cable Color	Black/Black

Mechanical Specifications

Shock	50g for 11mS duration
Vibration	35g up to 500Hz
Maximum Pressure	4.7 Bar
IP	IP65

Mounting

Thread	M16
Fitment	Universal Internal or External
Mounting	Horizontal

LS309-51N

LS Series—Level Sensor

Switching

Switch Action (Reed Switch)	SPST
Max Switching Voltage VDC	200
Max Switching Voltage VAC	250
Max Switching Current Amps	1
Max Switching Load Watt	70
Operate Mode	N/C with float horizontal
Contact Form	A

Technical Drawing

Internal Fitting

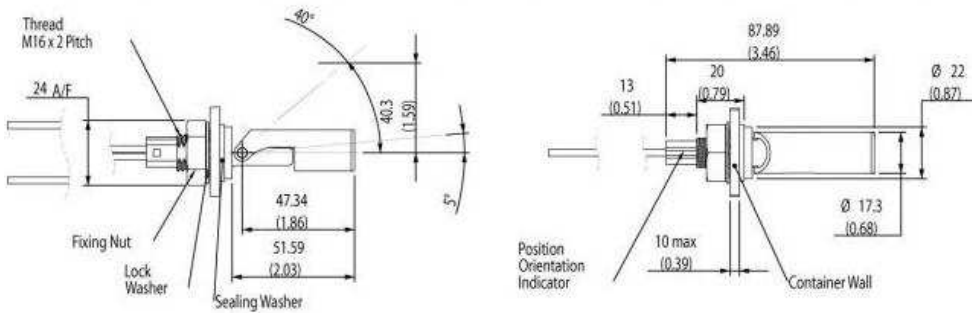

External Fitting

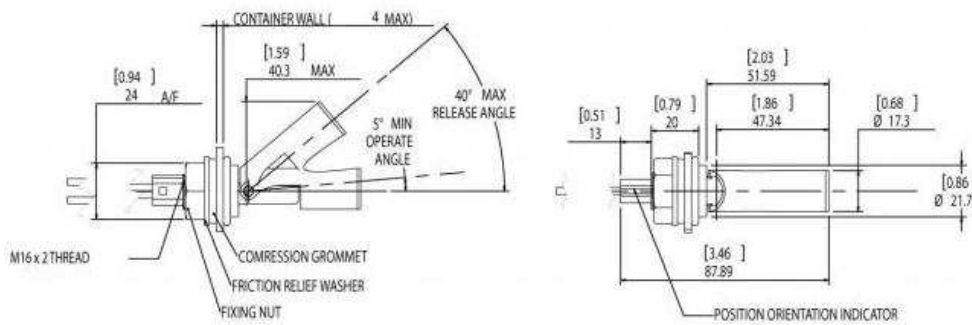

NORTH AMERICA & EUROPE

MEAS Deutschland GmbH
 a TE Connectivity Company
 Hauert 13
 D-44227 Dortmund
 Germany
 Phone: +49-(0)231-9740-0
 Fax: +49-(0)231-9740-20
 Email: info.de@meas-spec.com

ASIA

Measurement Specialties (China), Ltd.,
 a TE Connectivity Company
 No. 26 Langshan Road
 Shenzhen High-Tech Park (North)
 Nanshan District, Shenzhen 518057 China
 Tel +86 755 3330 5088
 Fax +86 755 3330 5099

te.com/sensorsolutions

Measurement Specialties, Inc., a TE Connectivity company.

Measurement Specialties, MEAS, TE Connectivity, TE Connectivity (logo) and EVERY CONNECTION COUNTS are trademarks. All other logos, products and/or company names referred to herein might be trademarks of their respective owners.

The information given herein, including drawings, illustrations and schematics which are intended for illustration purposes only, is believed to be reliable. However, TE Connectivity makes no warranties as to its accuracy or completeness and disclaims any liability in connection with its use. TE Connectivity's obligations shall only be as set forth in TE Connectivity's Standard Terms and Conditions of Sale for this product and in no case will TE Connectivity be liable for any incidental, indirect or consequential damages arising out of the sale, resale, use or misuse of the product. Users of TE Connectivity products should make their own evaluation to determine the suitability of each such product for the specific application.

© 2016 TE Connectivity Ltd. family of companies All Rights Reserved.